

ELECTROSTATIC LEVITATION IN COMB MICROACTUATORS

Anca TOMESCU, Mihaela GHITIU, Sorin ANTONIU
Electrical Engineering Dept., POLITEHNICA University – Bucharest
Răzvan Nicolae POPA
G&B-CONSULT, Bucharest

The influence of the electrostatic levitation force on the positioning of the mobile structure of a comb microactuator is studied by using two approximate analytical methods and a finite element numerical method.

INTRODUCTION

The increasing number of applications of microelectromechanic devices in industry, communications, medicine, military, and many other fields made them a subject of increasing interest. In particular, comb microactuators [1,2,3,4] are used extensively in communication resonant coupling devices or impact actuators. The structure of such microactuators is generally subjected to certain restrictions derived from the manufacturing process specific to the integrated circuit technology.

The design of a microdevice starts from a preliminary performance evaluation, with a view to establish the range of the proper design and manufacturing requirements. In this respect, the evaluation of the actuation (positioning) characteristic of the comb actuator, as well as its stability, is of foremost importance. However, the unavoidable presence of screening conducting planes introduces undesired levitation effects which have to be estimated from the very beginning. The present paper aims at estimating the influence of such electrostatic levitation effects on comb microactuators, in the limits of some reasonable simplifying assumptions.

DEVICE MODEL AND SIMPLIFYING ASSUMPTIONS

The microdevice under study [1,5] is an interdigitated structure consisting in two interleaved conducting comb structures, placed at the same elevation above a null potential conducting plane, with long comb teeth inserted in each other's comb gaps (fig. 1). The fixed comb structure can be connected at a driving (usually oscillating) potential V , while the mobile comb structure, maintained at null potential, can sustain a translation movement at a constant level above the reference plane, induced by the electrostatic forces associated with the driving potential applied to the fixed comb structure.

The presence of the conducting plane at null potential under both comb structures induces supplementary electrostatic forces on the mobile teeth in a direction normal to the horizontal reference plane and, thus, normal to the desired displacement of the mobile comb structure (fig. 2) – this is the electrostatic levitation. The ensuing vertical displacement of the mobile comb teeth alters the correct operation of the structure, with significant effects on the resonant frequency of the mobile comb structure. An evaluation of the levitation effect is therefore of great importance, and actions are to be devised with a view to reduce and even bar this effect.

Some simplifying hypotheses are supposed to apply:

- 1°. The tooth length is much larger than its width and height and than the distances to both neighbouring teeth and the reference conducting plane beneath;
- 2°. The teeth are symmetrically placed with respect to one another;
- 3°. The number N of the repetitive structure of interdigitated teeth is large enough so that the influence of the field asymmetry at the lateral edges of the comb structure is negligible.

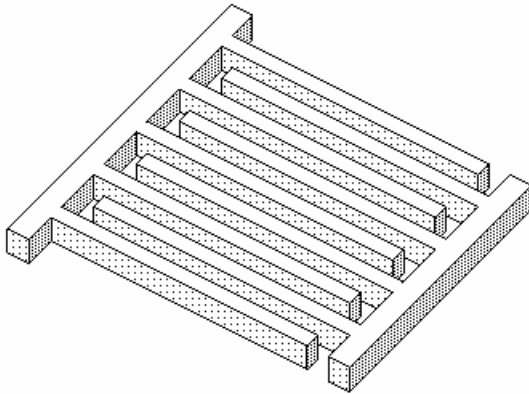

Fig. 1. Comb microactuator structure

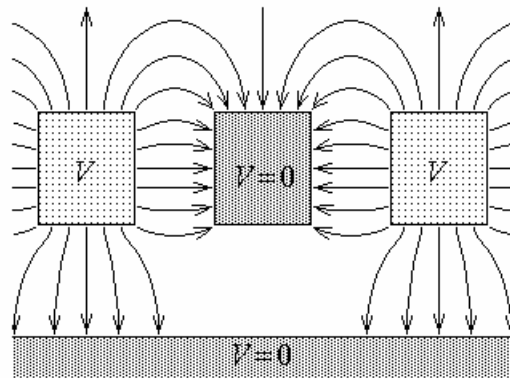

Fig.2. Field pattern in comb structure

According with the preceding simplifying hypotheses, one has to study the two-dimensional problem of the electrostatic field associated with a single mobile tooth in the neighbourhood of two fixed teeth. An $Oxyz$ reference system is considered, with the Oxz plane as the plane of symmetry of the mobile tooth and the Oxy plane as the basis plane of the fixed teeth, as in fig. 3. The following notations are introduced: tooth height h , mobile tooth width $2g$, fixed tooth width $2G$ ($G \geq g$), teeth elevation above the reference plane H , interteeth distance l . Considering the lateral symmetry of the structure, it is sufficient to apply the above equation and evaluate the vertical displacement of and vertical force on half the mobile teeth only (fig. 4).

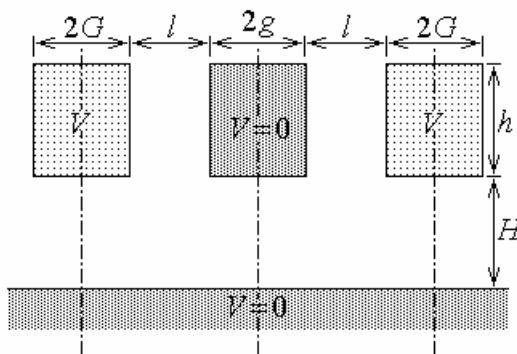

Fig. 3. Detailed comb microactuator structure

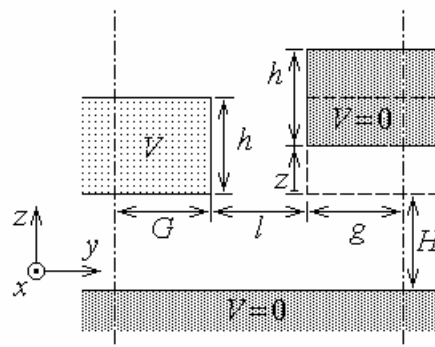

Fig. 4. Field computation structure

Under the analytical approach, the electrostatic levitation force is computed as

$$F = \left. \frac{\partial W^*}{\partial z} \right|_{V=ct.} = \left. \frac{\partial}{\partial z} \frac{CV^2}{2} \right|_{V=ct.} = \frac{V^2}{2} \frac{\partial C}{\partial z} ,$$

where W^* is the electric co-energy, C is the capacitance of the mobile tooth – fixed teeth system in the presence of the null potential reference plane, and z is the vertical displacement of the mobile tooth with respect to its reference position. The finite element numerical approach can give directly the value of the electrostatic levitation force.

The general, qualitative problem of the electrostatic levitation in comb microstructures is approached, so that the forces are evaluated in terms of their values per unit length, scaled with respect to $F_N = \varepsilon_0 V^2 / 2l$, for the simplest case where $H = h = G = g = l$.

COMPUTATION OF THE CAPACITANCE

The capacitance of the half-tooth comb microstructure is evaluated by two analytical methods – field line approximation and equipotential surface approximation [8,9,10] – and by a finite element numerical method [11].

The approximate expressions of the capacitance per unit length given by the field line approximation method are

$$C_L = \begin{cases} \varepsilon_0 \left[2 - \zeta + \frac{4}{\pi} \ln \left(1 + \frac{\pi \zeta}{4} \right) + \frac{1}{\pi} \ln \left(1 + \frac{\pi \zeta}{2} \right) + \frac{1}{\pi} \ln \left(1 + \pi - \frac{\pi \zeta}{2} \right) \right] & , \zeta > 0 \\ \varepsilon_0 \left[2 + \zeta + \frac{1}{\pi} \ln \left(1 - \frac{\pi \zeta}{2} \right) + \frac{1}{\pi} \ln \left(1 + \pi + \frac{\pi \zeta}{2} \right) \right] & , \zeta < 0 \end{cases} ,$$

where

$$\zeta = z/l .$$

The discontinuity in the capacitance values at $\zeta = 0$ was eliminated by applying a sliding average [12] of a $\Delta\zeta = 0.25$ half-width.

In the equipotential surface approximation method an expansion factor n was considered for the separation of equipotential surfaces above the mobile tooth along with an associated quadratic increase of this separation at corners, which gives the approximate expression of the capacitance per unit length as

$$C_S = \left(\beta - \frac{\pi}{2} \right) \left(\ln \frac{\alpha + \beta + \zeta}{\alpha + \pi/2 + \zeta} \right)^{-1} ,$$

where

$$\alpha = \frac{G + g + h}{l} , \quad \beta = \frac{\pi}{4} \left[\frac{3(n+1)}{2} - \sqrt{n} \right] \frac{\arctan \sqrt{n-1}}{\sqrt{n-1}} .$$

Finally, the arithmetic mean of the field line and equipotential surface approximations was used subsequently for the computation of the electrostatic levitation force.

The electrostatic field of the of the entire mobile tooth (two half-tooth) structure with $l = 2 \mu\text{m}$ was modelled, by the finite element numerical method, for discrete values only of the (relative) vertical displacement of the mobile tooth, namely $\zeta = -1, -0.5, 0, 0.5, 1, 1.5, 2$. The uniqueness conditions referring to boundary data are immediate: given V or null

potential on corresponding conducting surfaces, and homogeneous Neumann conditions on the remaining boundary, with the structure adequately extended above the teeth (five times the $h+H$ distance). The equipotential surface pattern confirmed the expansion of the equipotential surface separation accounted for in the equipotential surface approximation method, and indicated an expansion factor $n = 3$ (fig. 5).

COMPUTATION OF THE ELECTROSTATIC LEVITATION FORCE

The electrostatic levitation force is computed, again per unit length, according with equation

$$F = \frac{V^2}{2} \frac{\partial C}{\partial z} ,$$

starting with the values previously computed for the capacitance per unit length.

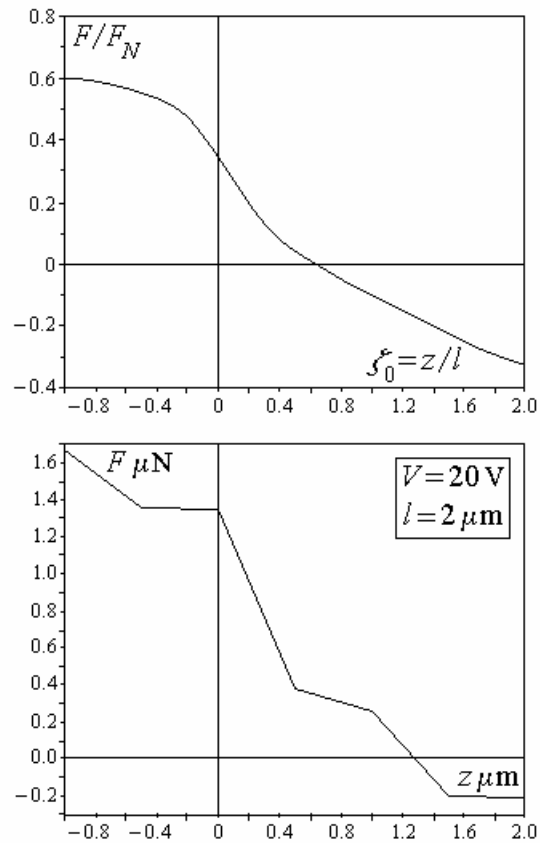
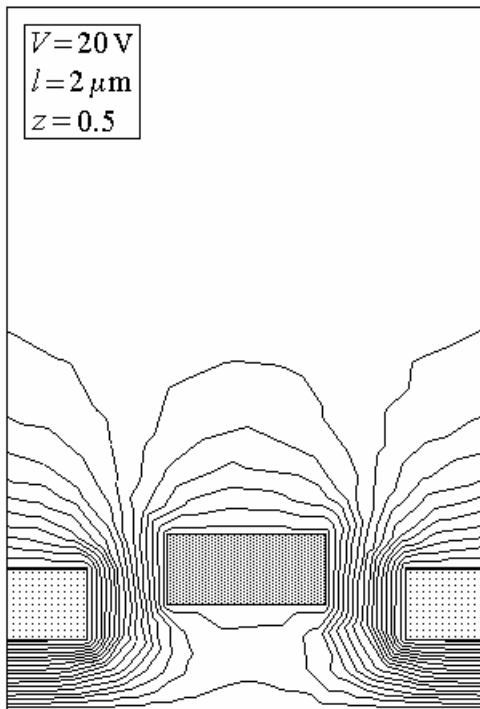

Fig. 5. Numerical modelling of equipotential surfaces

Fig. 6. Electrostatic levitation force

The analytical computation of the electrostatic force is straightforward and gives

$$F_L = \begin{cases} \frac{\epsilon_0 V^2}{2l} \left[\frac{4}{4 + \pi\zeta} + \frac{1}{2 + \pi\zeta} - \frac{1}{2(\pi + 1) - \pi\zeta} - 1 \right] & , \zeta > 0 \\ \frac{\epsilon_0 V^2}{2l} \left[1 - \frac{1}{2 - \pi\zeta} + \frac{1}{2(\pi + 1) + \pi\zeta} \right] & , \zeta < 0 \end{cases}$$

for the field line approximation, and

$$F_s = \frac{\varepsilon_0 V^2}{2l} \left(\frac{\beta - \frac{\pi}{2}}{\ln \frac{\alpha + \beta + \zeta}{\alpha + \pi/2 + \zeta}} \right)^2 \frac{1}{(\alpha + \beta + \zeta)(\alpha + \pi/2 + \zeta)}$$

for the equipotential surface approximation. The approximations of the force per unit length were further smoothed by applying a sliding average of a $\Delta\zeta = 0.25$ half-width, and their arithmetic average was taken as the analytic approximation of the electrostatic force.

The finite element modelling of the entire mobile tooth (two half-tooth) structure for the specified set of discrete vertical displacements of the mobile tooth offer as well a discrete set of values of the electrostatic force acting on the mobile tooth. An interpolation algorithm can be applied [11], along with a smoothing sliding average procedure.

Finally, as a measure of the electrostatic levitation influence, the null point of the electrostatic levitation force is determined acting on the mobile tooth (fig. 6), as $\zeta_0 = z_0/l \cong 0.638$ according with the analytical approximation (up), and $\zeta_0 = z_0/l \cong 0.645$ according with the finite element numerical computation (down).

CONCLUSIONS

The electrostatic levitation in a comb microactuator was studied, with a view to determine its influence on the mobile comb system. The average levitation force determined by analytical methods (field line and equipotential surface approximations) and by a finite element numerical method are in good agreement, and agrees also with published results [1].

Elimination of the electrostatic levitation influence on the comb microstructure can be achieved in principle by introducing a supplementary conducting plane at zero potential above the microactuator. Unfortunately, this is practically impossible to be done under the restrictions imposed by the manufacturing process. Alternative methods of eliminating the effect of the electrostatic levitation, such as double fixed comb systems under opposite applied voltages, remain to be studied.

ACKNOWLEDGEMENTS

Thanks are due to the staff of the Numerical Methods Laboratory, and to colleagues in the Group of Theoretical Electrical Engineering of the Electrical Engineering Department, "Politehnica" University of Bucharest.

REFERENCES

1. W.C. Tang, M.G. Lim, R.T. Howe, *Electrostatic Comb Drive Levitation and Control Method*, IEEE JMEMS, Vol 1, No. 4, December 1992, pp. 170–178.
2. W.A. Johnson, L.K. Warne, *Electrophysics of Micromechanical Comb Actuators*, IEEE JMEMS, Vol 4, No. 1, March 1995, pp. 49–59.
3. T. Hirano, T. Furuhashi, K.J. Gabriel, H. Fujita, *Design, Fabrication, and Operation of Submicron Gap Comb-Drive Microactuators*, IEEE JMEMS, Vol 1, No. 1, March 1992, pp. 52–59.
4. M.J. Daneman, N.C. Allen, W. Trimer, Y.-N. Jun, S. Erramilli, *Linear Microvibromotor for Positioning Optical Components*, IEEE JMEMS, Vol 5, No. 3, September 1996, pp. 159–165.
5. R.N. Popa, *Levitatia electrostatică în micro sisteme-piepteneu*, Graduation thesis, Department of Electrical Engineering, Polytechnic University of Bucharest, 2003.

ATEE – 2004

6. J. Van Bladel, *Electromagnetic Fields*, McGraw-Hill Book Company, New York, 1964.
7. H.A. Haus, J.R. Melcher, *Electromagnetic Fields and Energy*, Prentice Hall, Englewood Cliffs, J.J., 1989.
8. Anca Tomescu, F.M.G. Tomescu, R. Mărculescu, *Bazele electrotehnicii – Câmp electromagnetic*, MatrixRom, Bucharest, 2002.
9. Anca Tomescu, F.M.G. Tomescu, *Bazele electrotehnicii – Sisteme electromagnetice (Lecture Notes)*, Department of Electronics and Telecommunications, Polytechnic University of Bucharest, 1996.
10. Anca Tomescu, Mihaela Scărlătescu, *Capacitance bordering and approximation for microstrip lines*, Advanced Topics in Electrical Engineering ATEE – 2002, "Politehnica" University of Bucharest, December 2002.
11. Anca Tomescu, I.B.L. Tomescu, F.M.G. Tomescu, *Modelarea numerică a câmpului electromagnetic*, MatrixRom, Bucharest, 2003.
12. Anca Tomescu, F.M.G. Tomescu, *Transmisia informației (Lecture Notes)*, Department of Electrical Engineering, Polytechnic University of Bucharest, 1999.